

ECLIPSE RATIOMATIC BURNERS

Data 110-13

Model 2000 RM –Version 1.01

6/29/04

For Serial Numbers 95-5500 & Above

Specifications

Input vs. Chamber Pressure	23,200,000 Btu/hr. @ -5.0" w.c.	6800 kW @ -12.5 mbar
	22,000,000 Btu/hr. @ -3.0" w.c.	6448 kW @ -7.5 mbar
	20,700,000 Btu/hr. @ -1.0" w.c.	6067 kW @ -2.5 mbar
	20,000,000 Btu/hr. @ 0.0" w.c.	5862 kW @ 0.0 mbar
	19,300,000 Btu/hr. @ +1.0" w.c.	5657 kW @ +2.5 mbar
	18,600,000 Btu/hr. @ +2.0" w.c.	5452 kW @ +5.0 mbar

Input may be increased by 20% if sufficient secondary air is available to complete combustion.

Minimum Input 200,000 Btu/hr. (58.6 kW) with neutral chamber. Will be slightly higher with negative chamber pressure.

Turndown 100:1 with neutral chamber pressure.

Configurations	Burner Configuration	Max. Chamber Temp.
	Burner with alloy tube	1500° F (538° C)
	Burner with refractory block	1800° F (982° C)

Maximums shown are for average installations. Depending on conditions, higher temperatures can be obtained. Contact Eclipse for details.

Fuel Standard nozzle burns natural gas, propane, propane/air mixes without changing internals. Contact Eclipse for other fuels.

Gas Inlet Pressure at the proportionator inlet	Minimum: 30" w.c. (75 mbar)	natural gas, .65 s.g.
	Maximum: 2 psig (138 mbar)	natural gas, .65 s.g.

Pilot Gas Pressure at the pilot cock inlet	Minimum: 6" w.c. (15 mbar)	natural gas, .65 s.g.
--	----------------------------	-----------------------

High Fire Flame Length 150" (3.81 m)
Measured from the end of the firing tube, firing parallel to air flow with neutral chamber pressure. When firing perpendicular to air flow, flame length will be shorter. Contact your local Eclipse representative for details.

Piloting Integral spark-ignited pilot; ignition plug included.

Flame Monitoring By UV scanner only. Scanners & mounting kits are available from Eclipse.

Control Motor Requirements 90° travel with full stroke timing of 15 seconds or longer. Ovens with high chamber drafts or backpressures may require less than a full 90° stroke. In these cases, use adjustable stroke motors or motors equipped with travel-limiting auxiliary switches.

Emissions Ratiomatics produce low NO_x, CO and aldehydes. Emissions performance depends not only on the burner, but also factors such as chamber temperature, chamber design, and heat loading. For estimates of Ratiomatic performance in your application, call Eclipse.

Packaging Options IRI or NFPA type valve trains, and UL recognized valve packages available.

CAUTION: It is dangerous to use any fuel burning equipment unless it is equipped with suitable flame sensing devices and automatic fuel shut-off valves. Eclipse can supply such equipment or information on alternate sources.



Dimensions, 2000 RM

Dimensions are subject to change without notice. Contact Eclipse for certified prints prior to fabrication or installation.

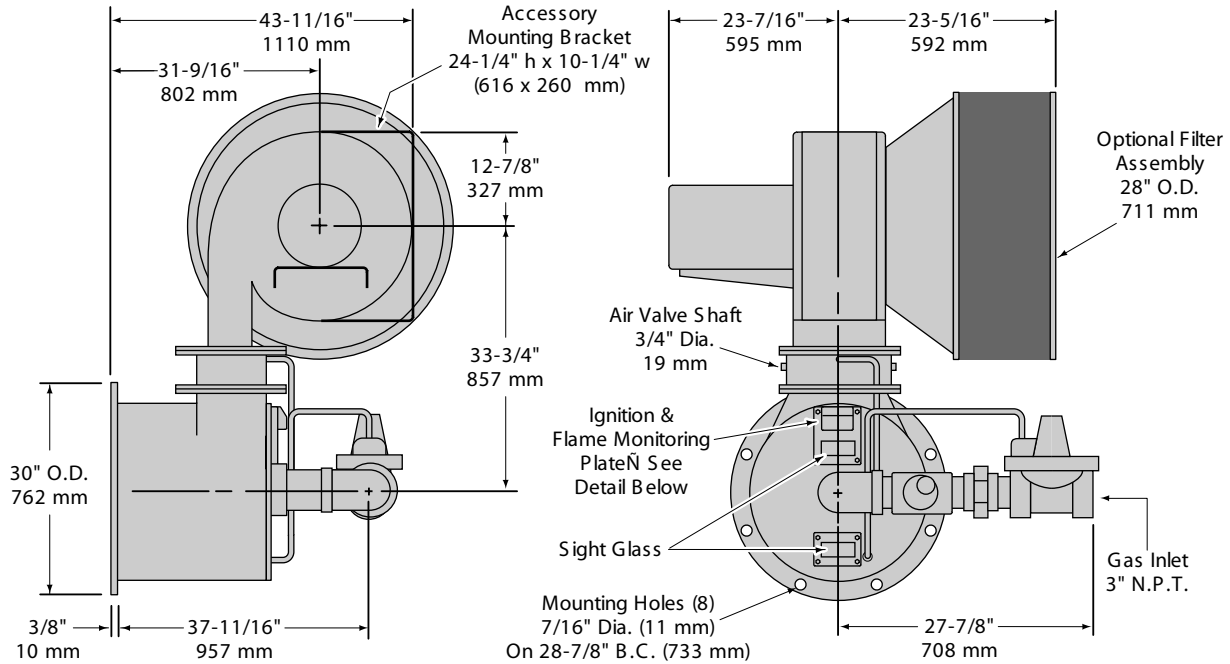

Alloy Tube Assembly – #110281

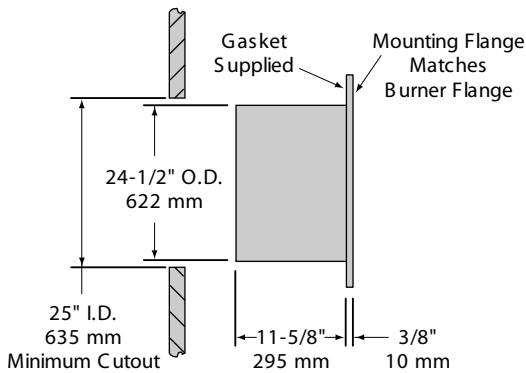

Block & Holder Assembly – #187297-61

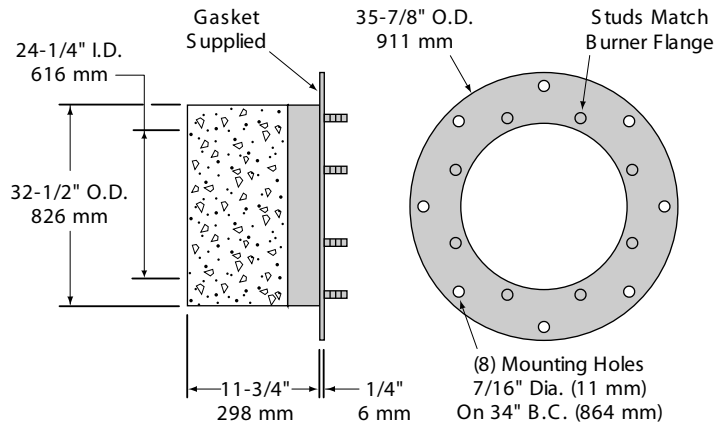

Flame Monitoring Plate Detail

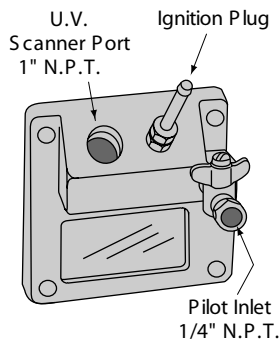

Component Information

Item	Description	Part #
2000 RM Burner Assembly		
	w/Alloy Tube; Left Hand Blower (shown)	110414
	w/Alloy Tube; Right Hand Blower (motor opposite side)	110404
	w/Block & Holder; Left Hand Blower (shown)	110444
	w/Block & Holder; Right Hand Blower (motor opposite side)	110434
Air Filter Assembly	Optional	110287
Replacement Filter Elements	---	15608 & 10411
Spark Plug ¹	For burner with tube or block.	150000-12
Blower Motor ¹	20 hp, 230/460/3/60 TEFC, 3600	19894
Proportionator ¹	Eclipse ES 369, 3"	10316
Pilot Cock ¹	Eclipse lever handle, 1/4"	12659
Gas Adjusting Butterfly ¹	Eclipse 112 BV, 3"	500993

¹ Included with burner assembly.

Block & Holder and Alloy Tube are interchangeable in the field.



ECLIPSE COMBUSTION



Offered By:

Power Equipment Company
2011 Williamsburg Road
Richmond, Virginia 23231
Phone (804) 236-3800
Fax (804) 236-3882

www.peconet.com